

# Framework Napkins

by Heather Seth & Elise Lea for TIDE + LOOM

Finished size: 19" x 19"



Fruitful Delights - Page 2

## Fabric Guide

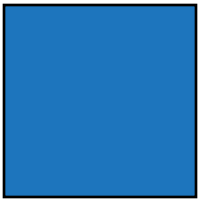

**Napkins**  
5/8 yard

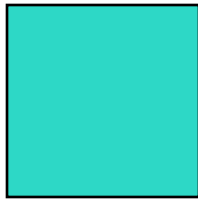

**Napkins**  
5/8 yard

Each 5/8 yard makes 2  
napkins.

*Kindly note, our free patterns are not to be sold nor hosted on any other websites. We appreciate your understanding.*

All seam allowances are 1/4" unless otherwise stated.  
Press seams open unless otherwise stated.

WOF = Width of Fabric (selvage to selvage)  
RST = Right Sides Together

## Cutting Instructions

From each fabric | Cut two 20" squares

## Sewing Instructions

**Step 1:** Fold and press all edges 1/4" wrong sides together. Fold over another 1/4" and press again.

**Step 2:** Open the corners back up and trim along the line shown below, using your pressed lines as a guide.

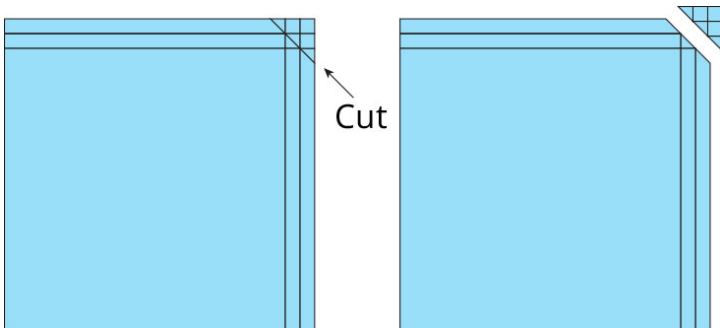

**Step 3:** Fold over and press the trimmed corner 1/4" wrong sides together.

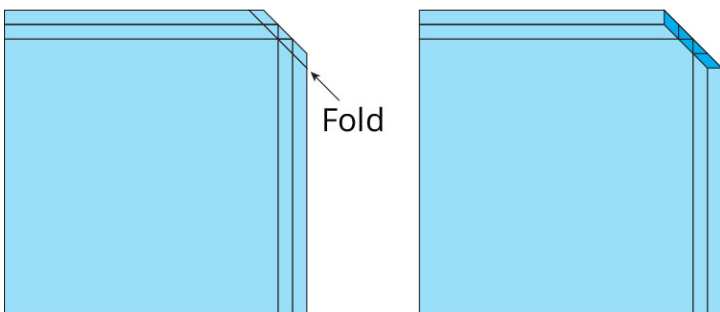

**Step 4:** Repeat Steps 2-3 for all 4 corners.

**Step 5:** Refold napkin along original 1/4" fold line and press. Refold along the second 1/4" fold line and press.

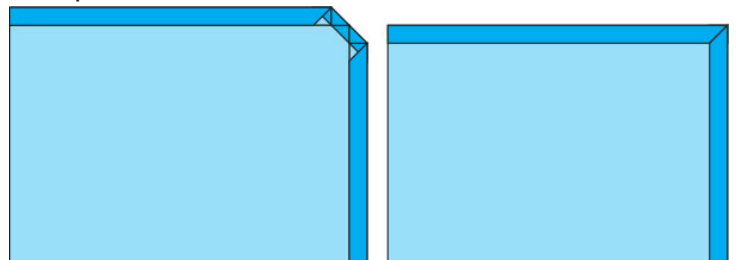

**Step 6:** Topstitch around the entire napkin, close to the edge of the hem.

Repeat to make desired number of napkins.

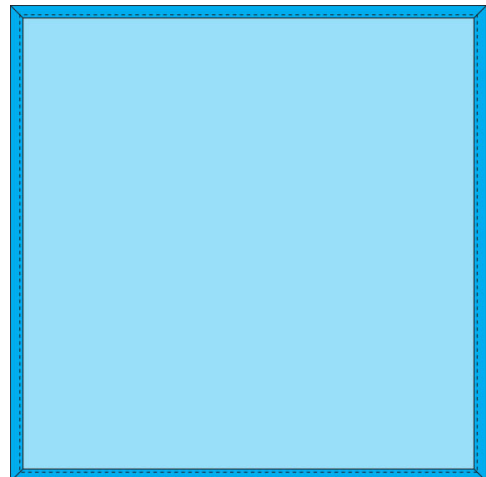

**Woohoo!** Your Napkins are now finished!

# Fruitful Delight



## Fabric Guide



**Napkins**  
T110-001-783  
5/8 yard

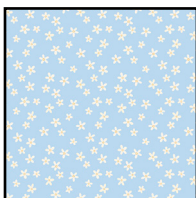

**Napkins**  
T110-005-713  
5/8 yard

Each 5/8 yard makes 2  
napkins.